

O/Δ Af. Bl. fl., Pro/Toxpro alljährlich I

Musical notation with notes and a graphic of a horizontal bar with a curved line above it.

fr k k t h s — fr k k t p t h s s t k

x2

Handwritten musical notation with notes and a graphic of a horizontal bar with a curved line above it.

Graphic notation with wavy lines and arrows, and a box containing musical notation.

(sowohl i. d. Bew. als auch in jol. Wh. wird.)

Graphic notation with rectangular blocks and arrows.

Musical notation with notes and arrows.

(etwas lieblich)

Graphic notation with vertical lines and arrows.

Musical notation with notes and arrows, and a box containing musical notation.

perpendici

o [fr - k - k - p - t | s - s s - t | k p p]

Graphic notation with wavy lines and arrows.

i - no - na - ma - m2 - ni - o - n2 - v/2 - ni - ni - ni - o - a - ka - nu - v/2

(solo voce) monoton, verschmelzend

etow

[i - no - na - na - ma - v/2 - ni - ni - ka - ma - ti - ti - ti - v/2]

(come sopra)

	3-4 Sp.	.P. / .P.	Eyes I
--	---------	-----------	--------

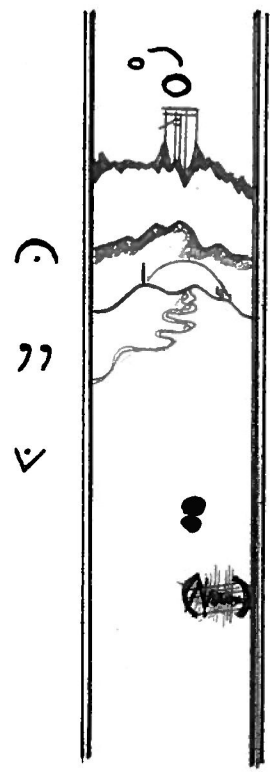
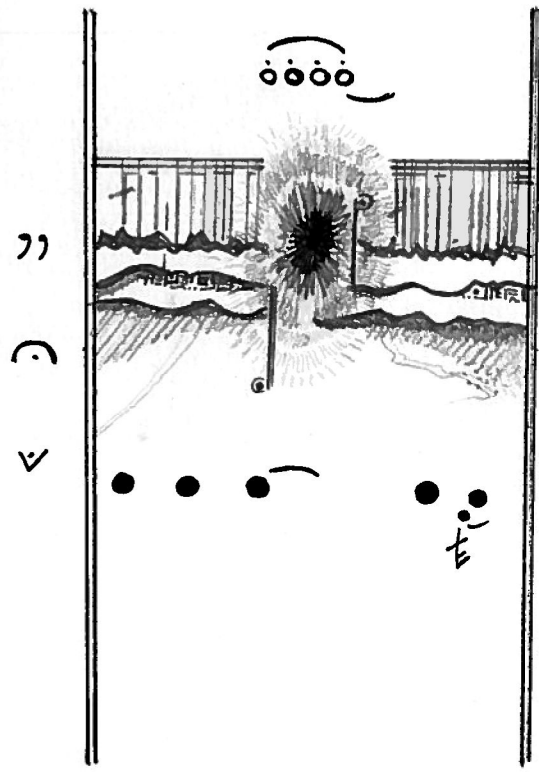
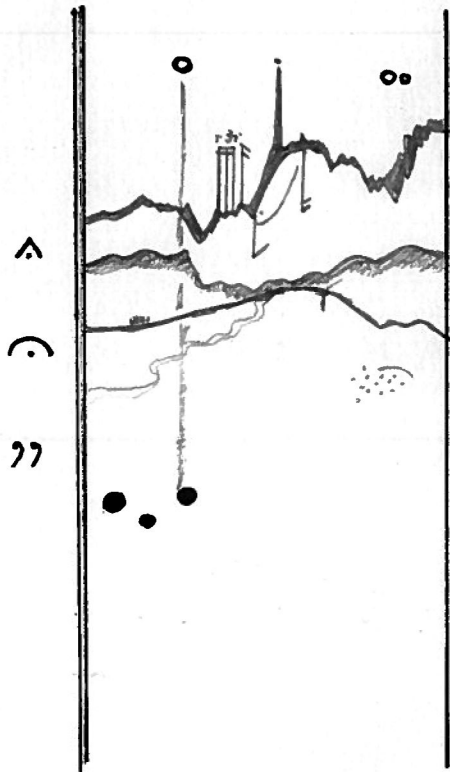
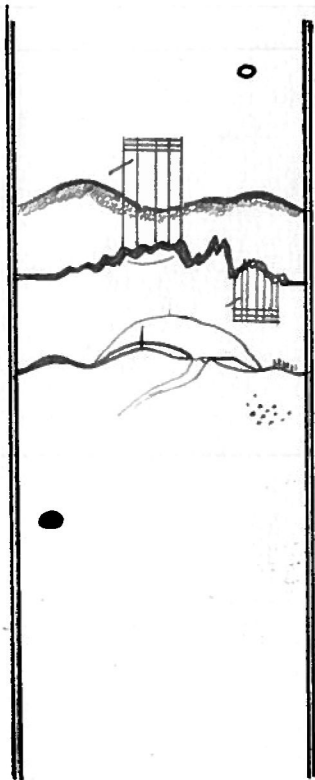

Δ	5 Sp.		Eyes II (Isthmus)
----------	-------	--	-------------------

J. = 54-63 J. J. J. J. etc.

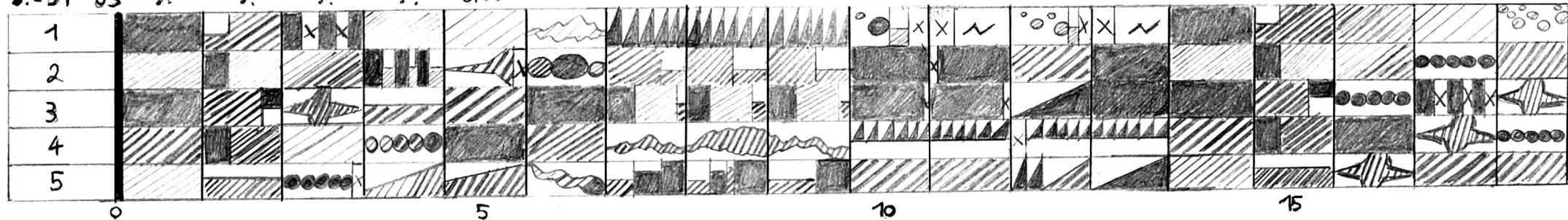

//

J. J. J. J. etc.

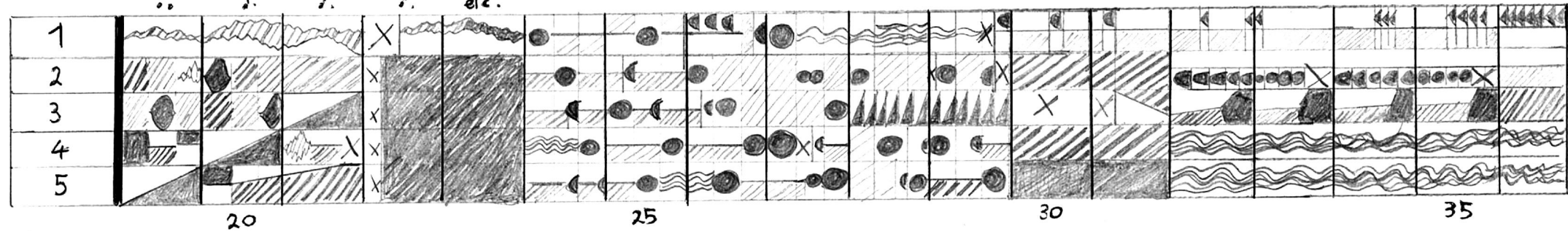

//

J. J. J. J. etc.

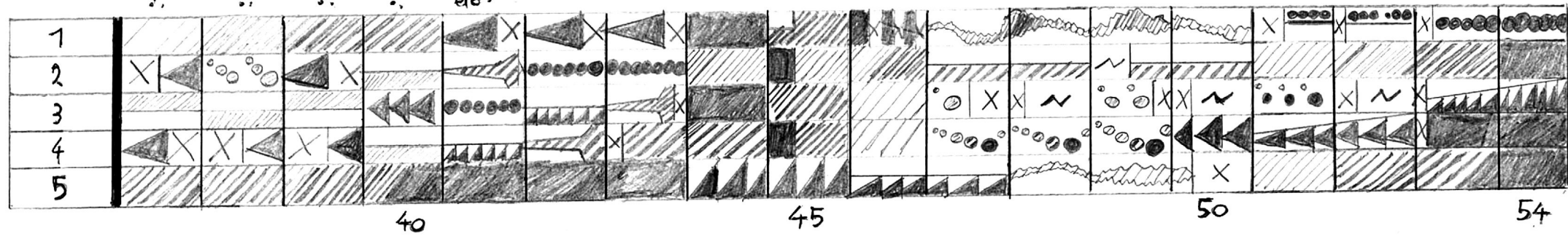

Calmo.

The image shows a handwritten musical score on a page with horizontal lines. The score is titled "Calmo." and is written in black ink. It features a complex arrangement of staves and graphical elements. The notation includes various note values, rests, and dynamic markings. There are several instances of rectangular boxes with vertical hatching, possibly representing specific musical techniques or effects. A prominent diagonal line runs across the score, intersecting multiple staves. The score is divided into sections by vertical lines, and there are several instances of the letter "A" and "C" in parentheses, likely indicating specific measures or sections. The overall style is that of a working draft or a composer's sketch.

Con sord.

○	Ten. bl. fl., Kbs.	$\begin{matrix} \cdot & \cdot \\ P \\ (-) \end{matrix}$	Eyes IV
---	--------------------	---	---------

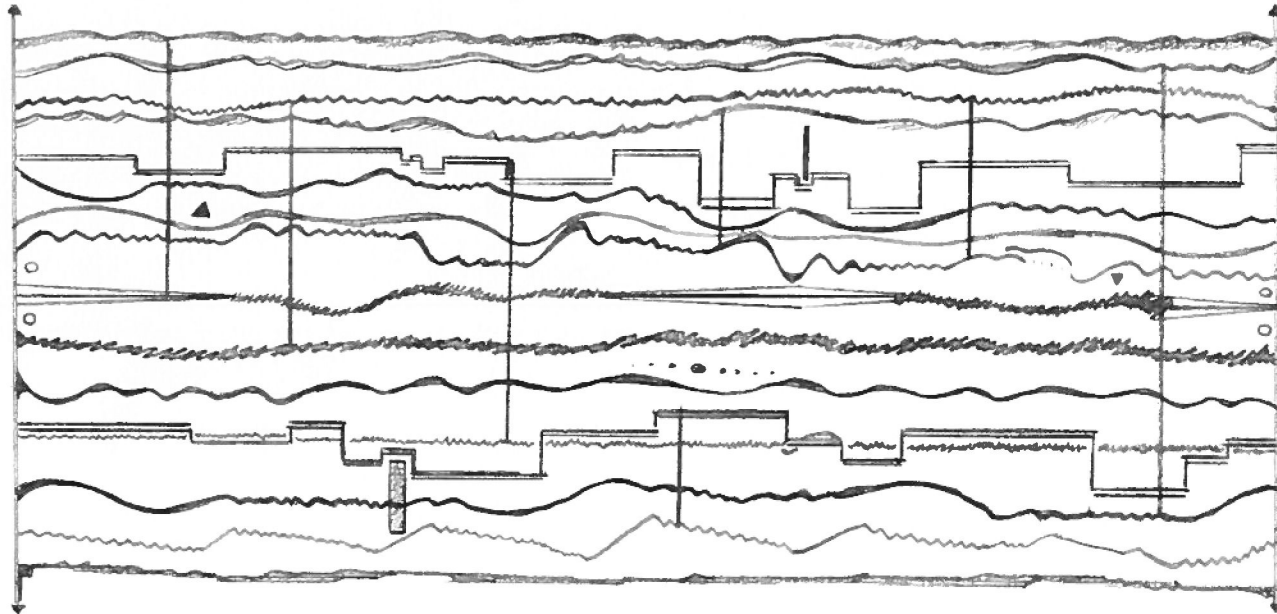

pp-mp, cresc. ad lb.

○	Pno. solo (+ x Instrumente)	p	Filter I+II
---	-----------------------------	---	-------------

Handwritten musical score for piano solo, consisting of six staves. The notation is dense and includes various musical symbols such as notes, rests, and dynamic markings. Annotations include:

- Staff 1: (S), (W)
- Staff 2: (shift)
- Staff 3: (S), (W)
- Staff 4: 36HT (38w) Mitted. Klavier, (shift)
- Staff 5: (S), (W)
- Staff 6: (trando)

○ Pro. solo (+x instruments) p Filter I+II

A handwritten musical score for piano solo, consisting of approximately 12 staves. The notation is dense and includes various musical symbols such as notes, rests, and dynamic markings. Key annotations include:

- Staff 1:** Circled notes and a box containing 'S' and 'W'.
- Staff 2:** A circled note and a box containing 'S' and 'W'.
- Staff 3:** A circled note and a box containing 'S' and 'W'.
- Staff 4:** A circled note and a box containing 'S' and 'W'.
- Staff 5:** A circled note and a box containing 'S' and 'W'.
- Staff 6:** A circled note and a box containing 'S' and 'W'.
- Staff 7:** A circled note and a box containing 'S' and 'W'.
- Staff 8:** A circled note and a box containing 'S' and 'W'.
- Staff 9:** A circled note and a box containing 'S' and 'W'.
- Staff 10:** A circled note and a box containing 'S' and 'W'.
- Staff 11:** A circled note and a box containing 'S' and 'W'.
- Staff 12:** A circled note and a box containing 'S' and 'W'.

Other notable markings include '36HT (3P)', 'Filter Klavier', and 'stiff'. The score is characterized by frequent use of circles around notes and boxes around specific symbols, suggesting a focus on these elements. The bottom of the page features rhythmic patterns represented by arrows and dots.

△ Pno. 8-12 Hd. P Hands I

The first system of the handwritten musical score consists of five staves. The notation is dense, featuring numerous triplets and sixteenth-note runs. Fingerings are indicated by numbers 1-5. Above the staves, there are several bracketed groups of notes with the number '3' written above them, indicating triplet patterns. The music is written in a single system, with a double bar line appearing after the second staff. The notation includes various rhythmic values and articulation marks.

The second system of the handwritten musical score continues the complex rhythmic patterns from the first system. It also consists of five staves. This system features a prominent section with repeated sixteenth-note patterns, marked with 'x2' and 'x2-4' above the staves. There are also several instances of '5:4T' markings, likely indicating a 5/4 time signature or a specific rhythmic pattern. The notation is highly detailed, with many notes and rests. The system concludes with a double bar line and some final markings, including '(2 ff: 7-5)' and 'x4-7'.

3 Kbs. 6-händig P Hands II

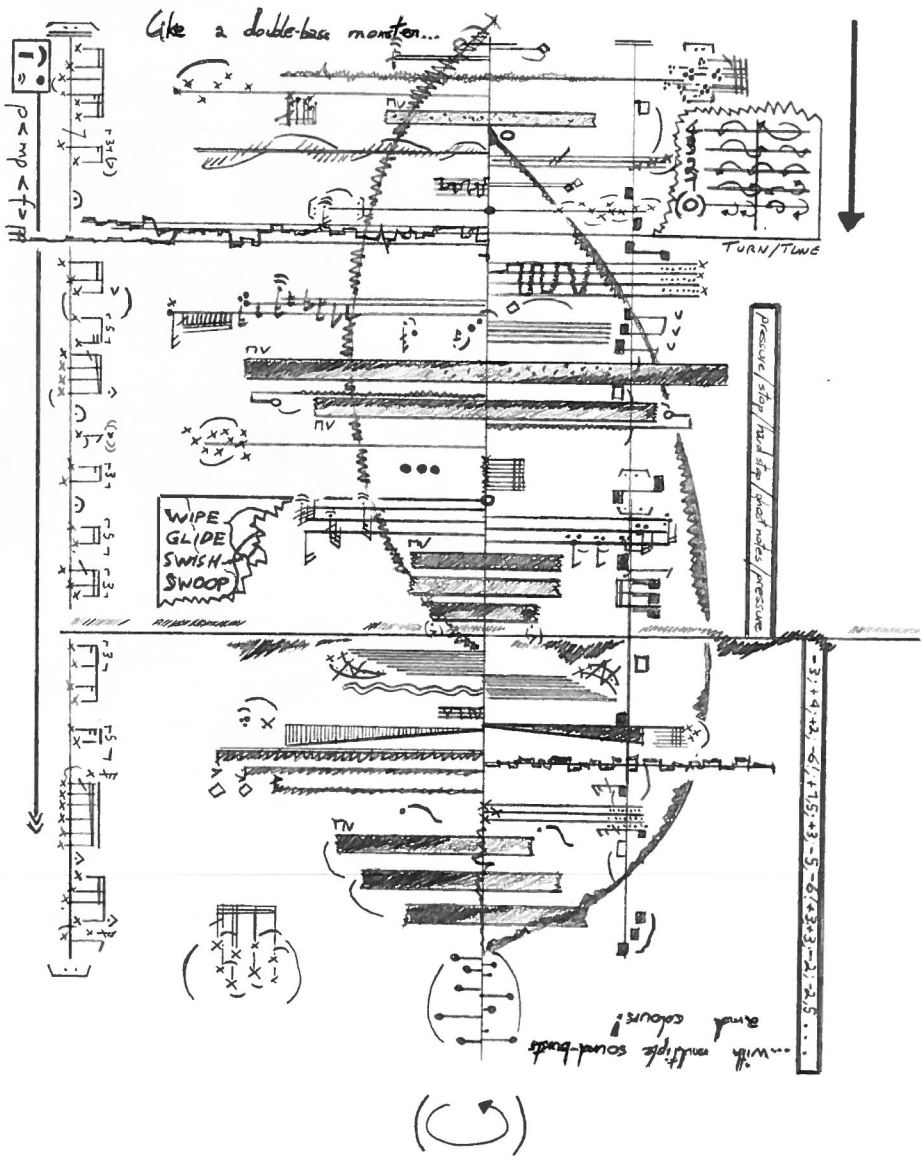

O/800 Sci. solo p Hands III

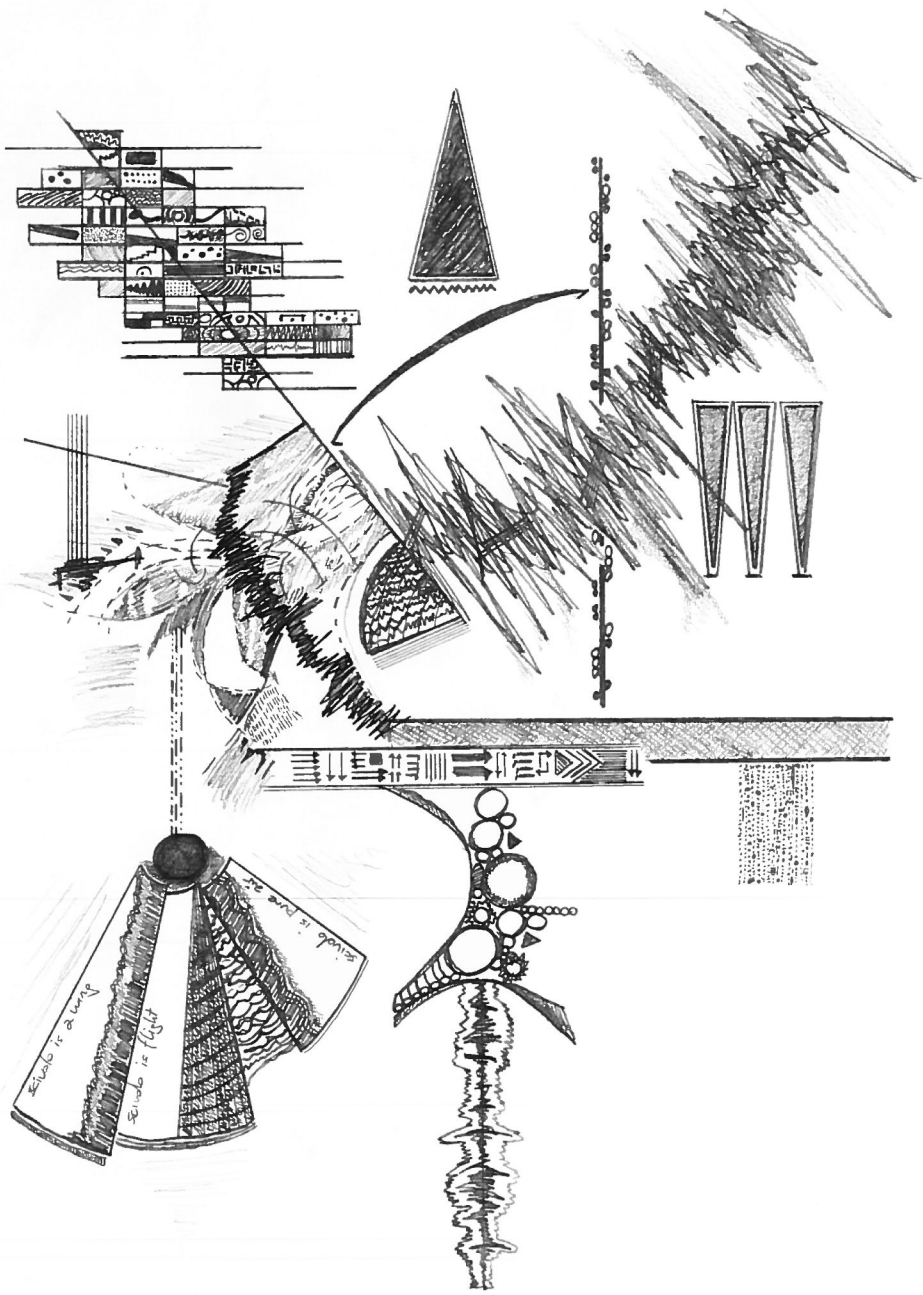

△	2 Bl.f.	p	Hands IV
---	---------	---	----------

Gemessen. Mit Raum,
ohne Hast.

(cempre initando)

rit.

decresc. ---

The score consists of several staves and diagrams. At the top left, there is a diagram of a hand with fingers numbered 1-4 and notes on a staff. Below it is a staff with notes and rests, starting with '(cempre initando)'. To the right, there are several staves with notes and rests, some with dynamic markings like 'rit.' and 'decresc.'. There are also some abstract diagrams and scribbles, possibly representing fingerings or performance techniques. The notation includes various note values, rests, and dynamic markings.

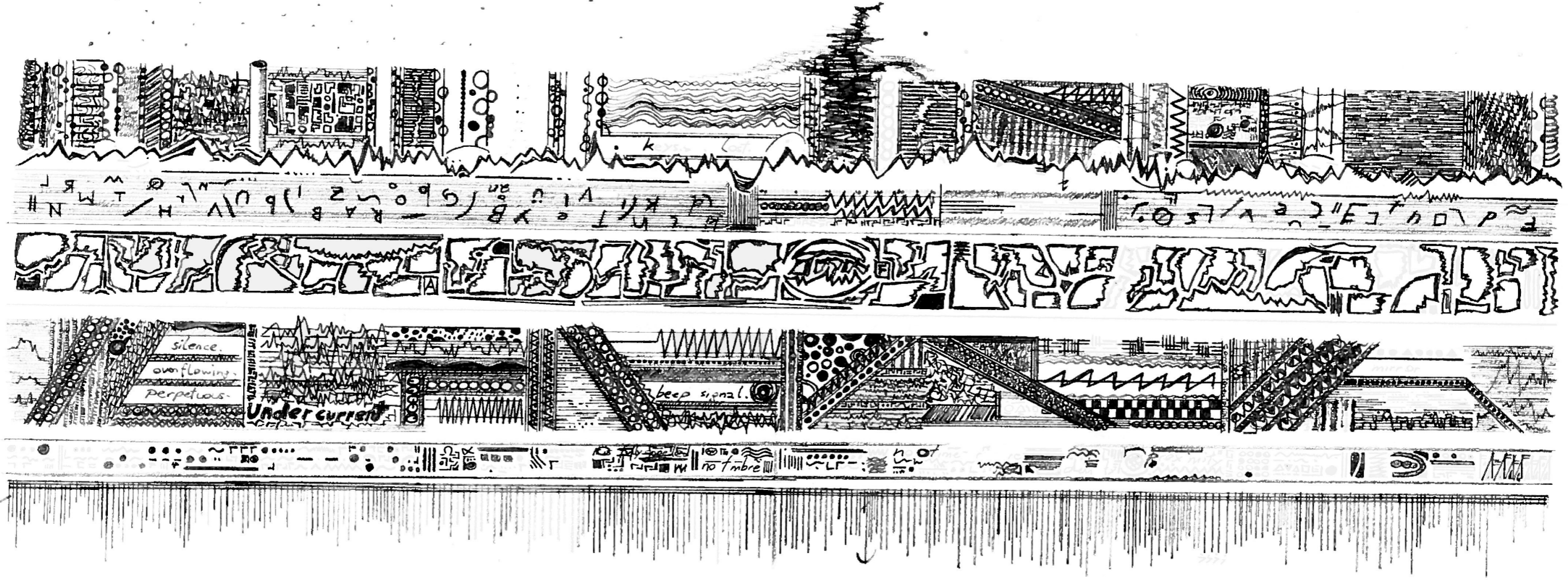

3	1-x Sp.	i:P:	Head II
---	---------	------	---------

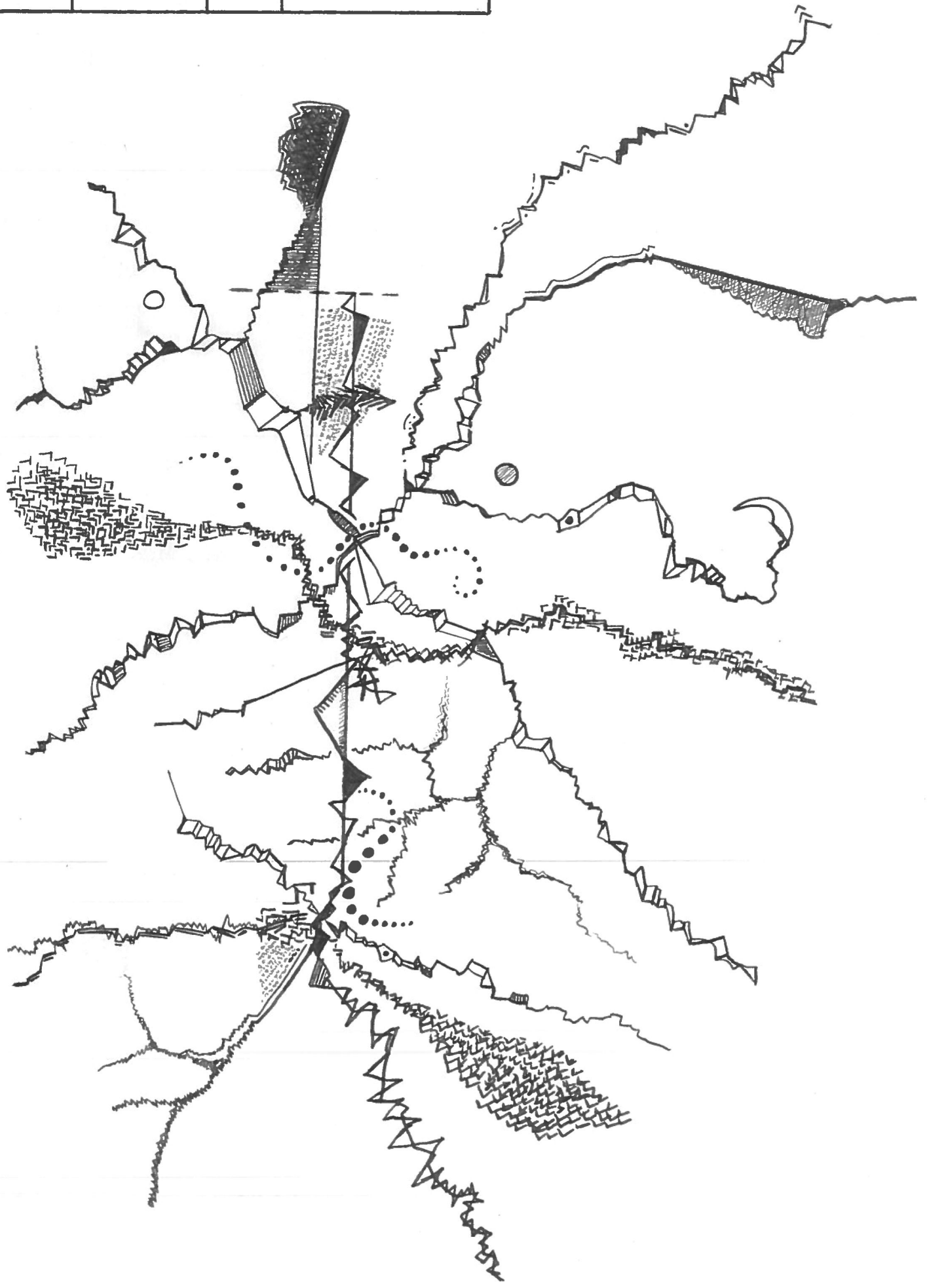

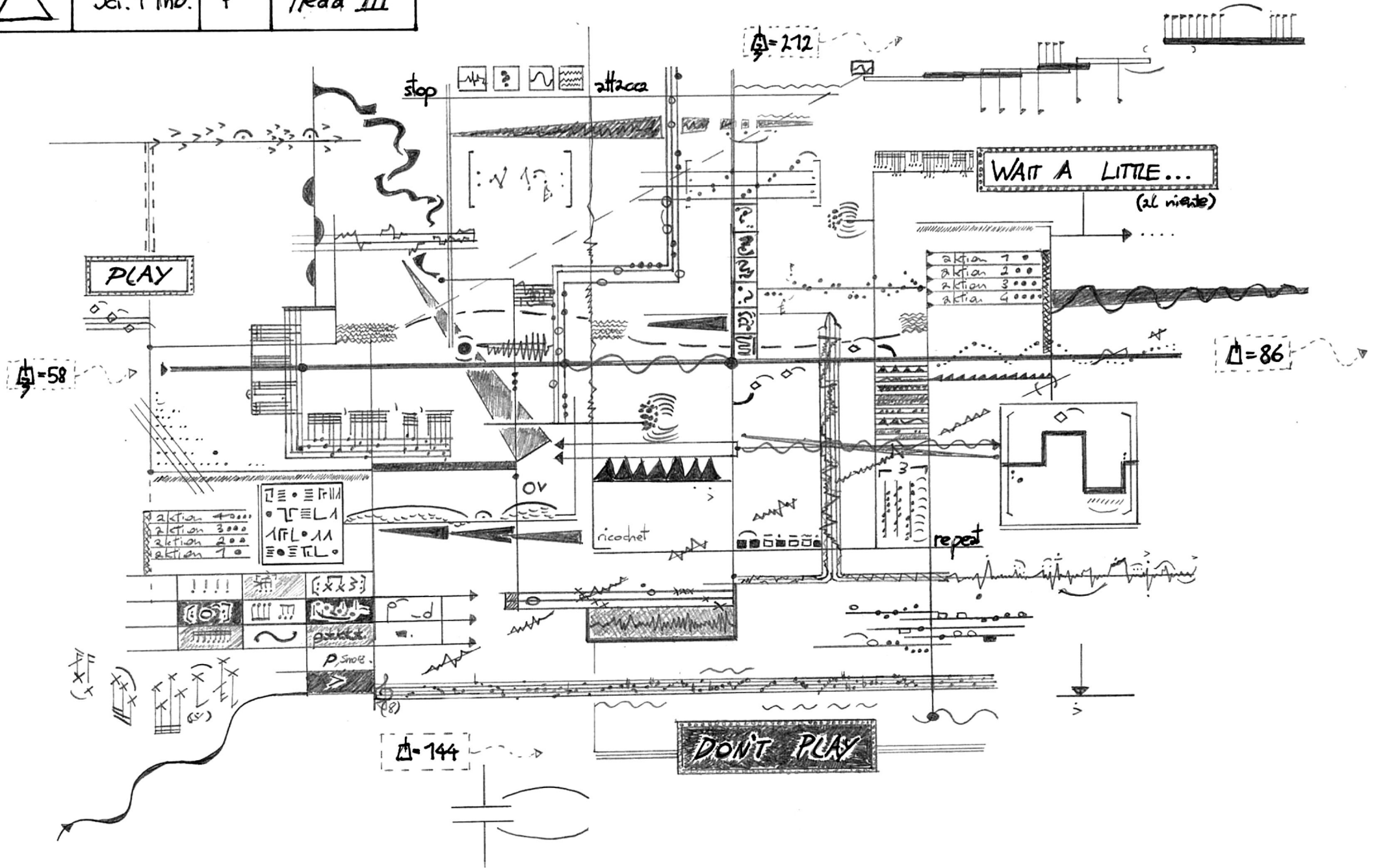

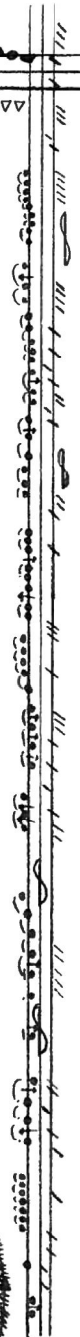
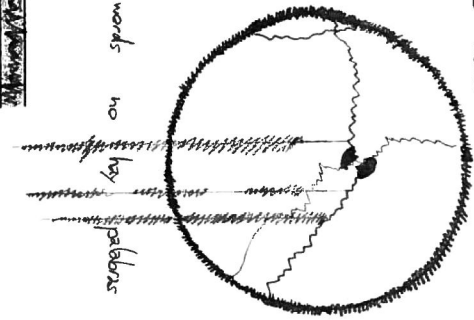
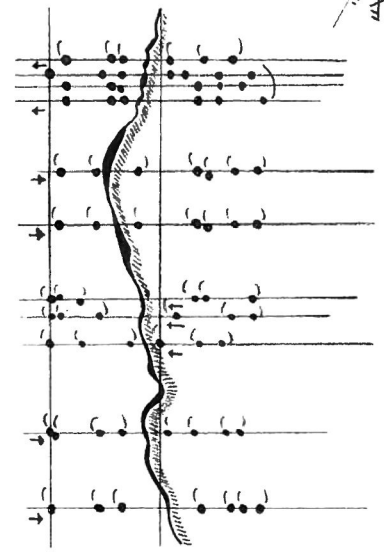
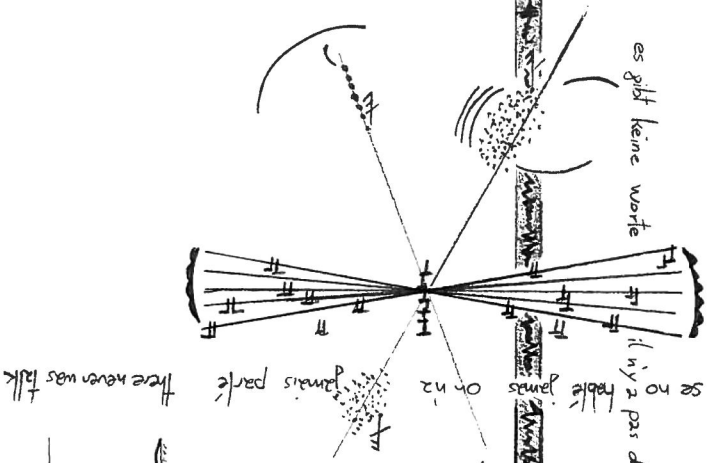
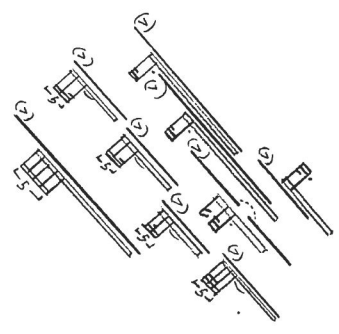
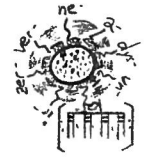
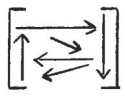

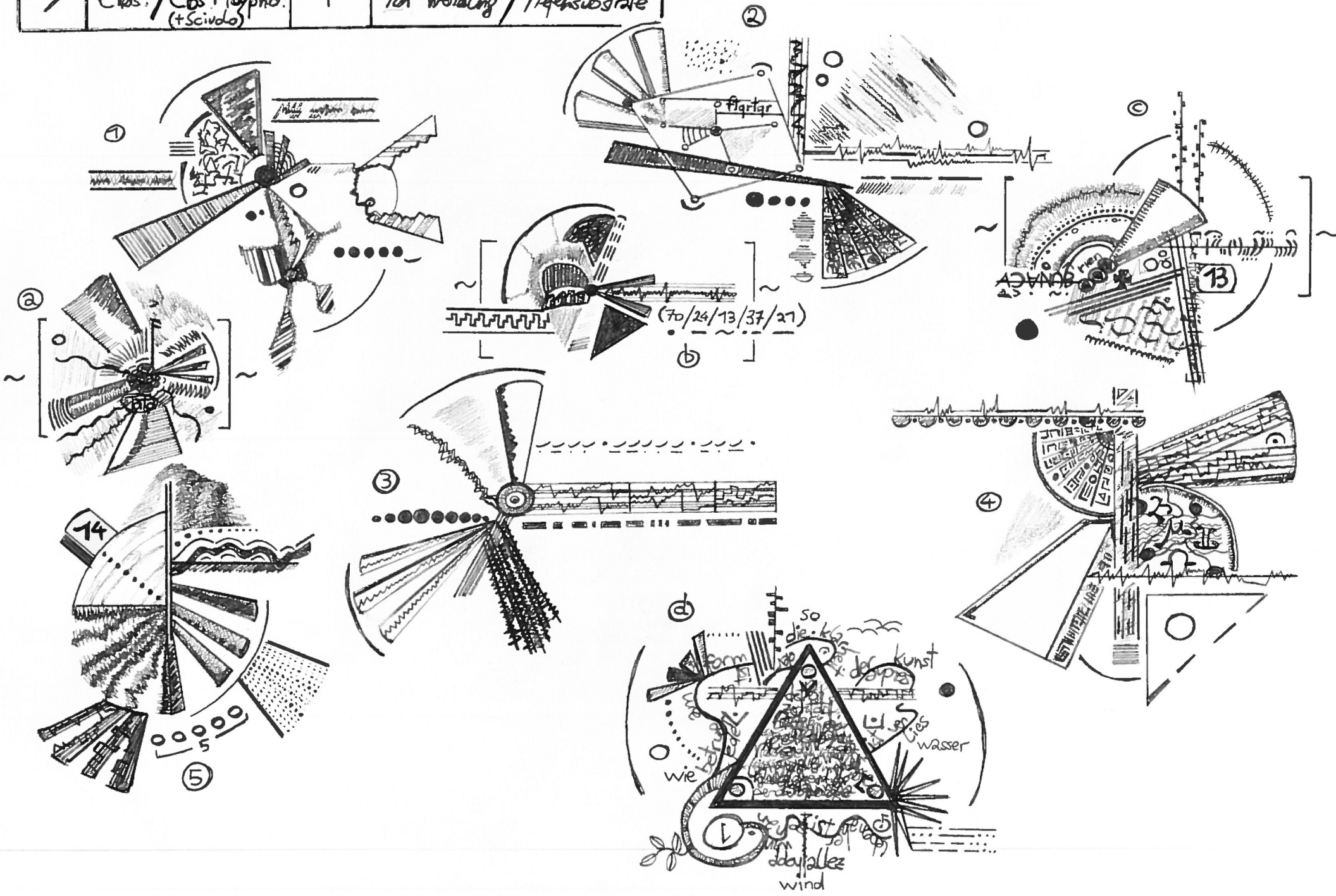



3 Fl./Bl-fl. (+ 1 Sp. * Pho.)

• P / • P_{co}

Mauern, Köpfe, Zeichenhaftigkeit

(Kanon)

1.



//



//



//



(quasi maestoso, mit großen festus smf)

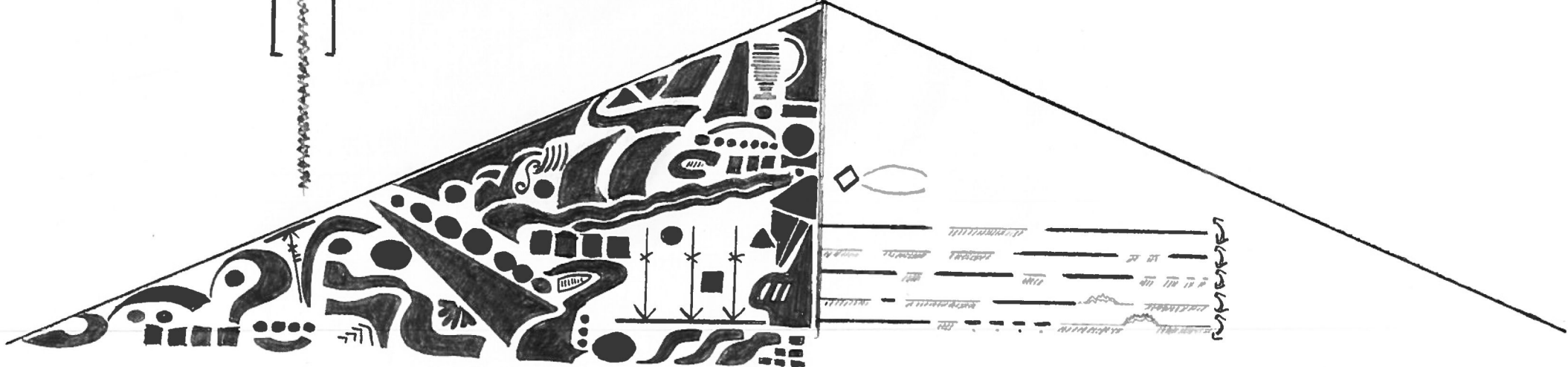

7
1 Sp. (Si.) / 3-4 Sp.
P
momentan, die Unendlichkeit

$\Delta = 80 \rightarrow / \vdash \vdash \vdash \vdash \vdash (E4) \nabla \nabla$

$\nabla = 187 \rightarrow / \vdash \vdash \vdash \vdash \vdash \vdash \vdash \vdash \vdash \vdash \nabla$

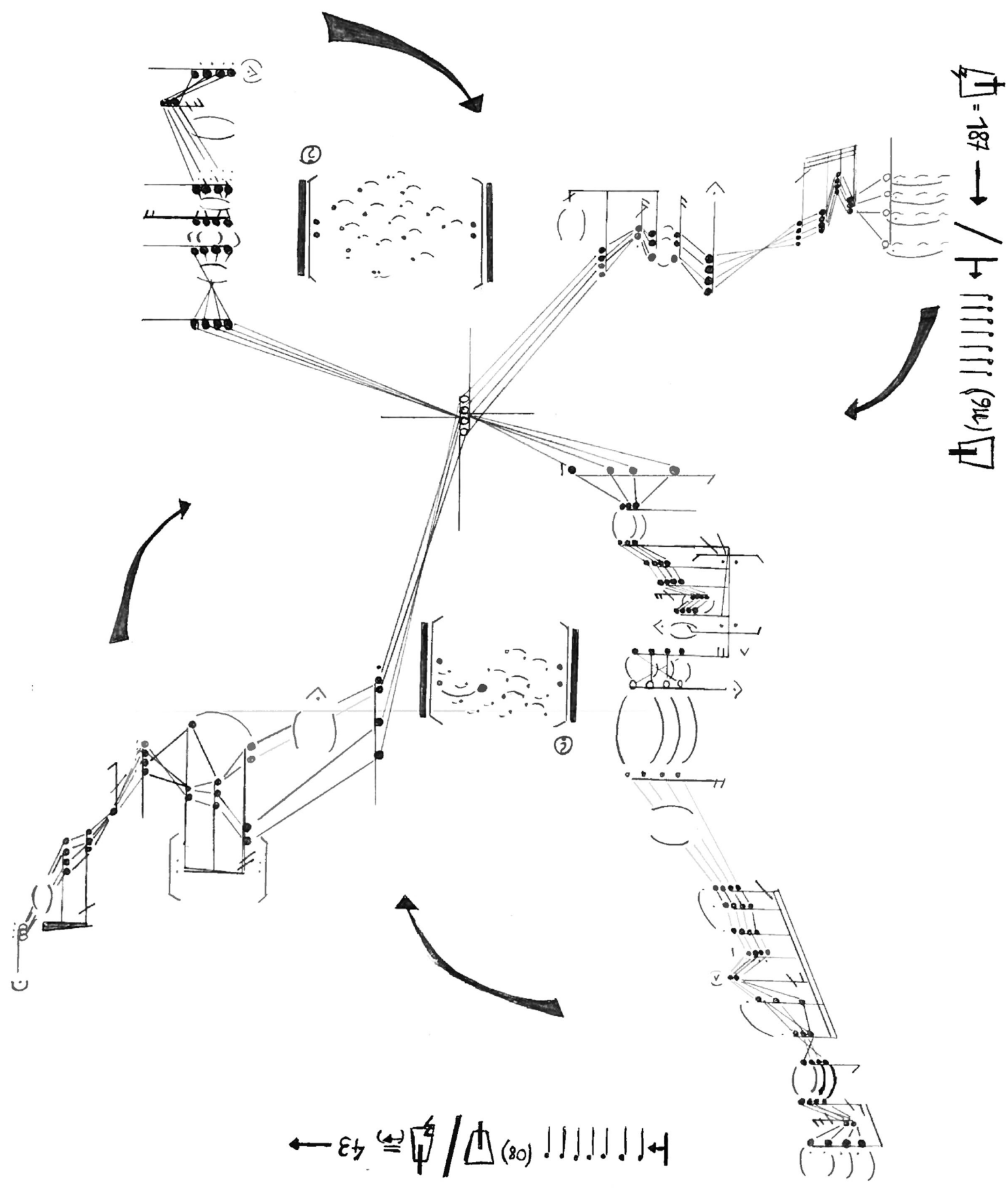

Δ Bs. bl. fl., Cbs. ð Nesten, Fluchten, Königs kinder

Calmo, deciso, subtil.



wen freischwebend
gäh

bleiben

nein

(iv)

(kckett)

(v)

wes'

brat

es bricht...

Liede affink...

(ø/hypod)

(determinant)

die ende hinter sich
lässt

(=)

[and]

[many more such stories]

(niemals heutig)

in was geschick für so viel zeit
das es kommt freudlos in vision
wahrheit und kaisers
1977

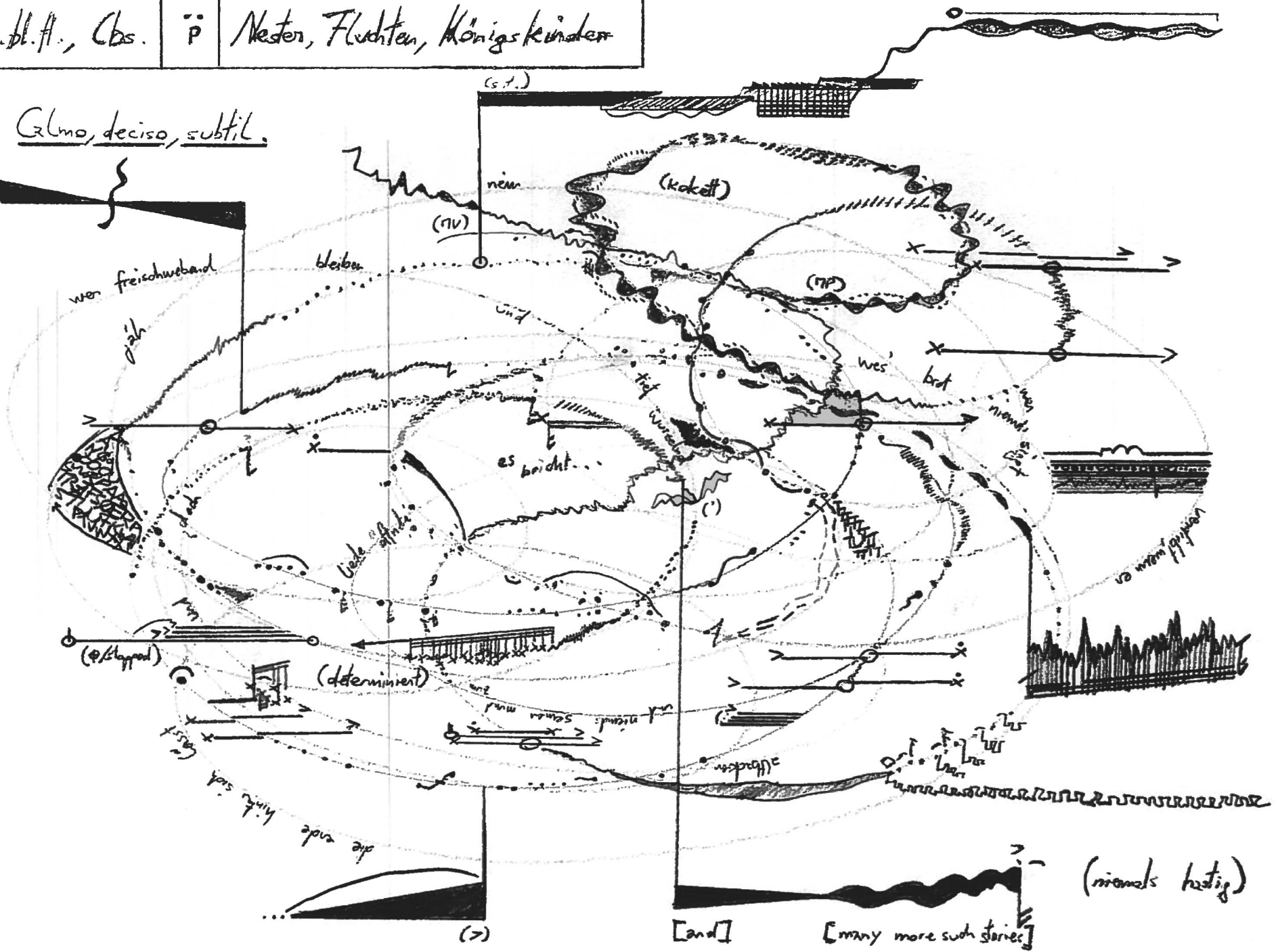

□ □ □ 2 Sp. · P. Plade, Füße, Gravitation

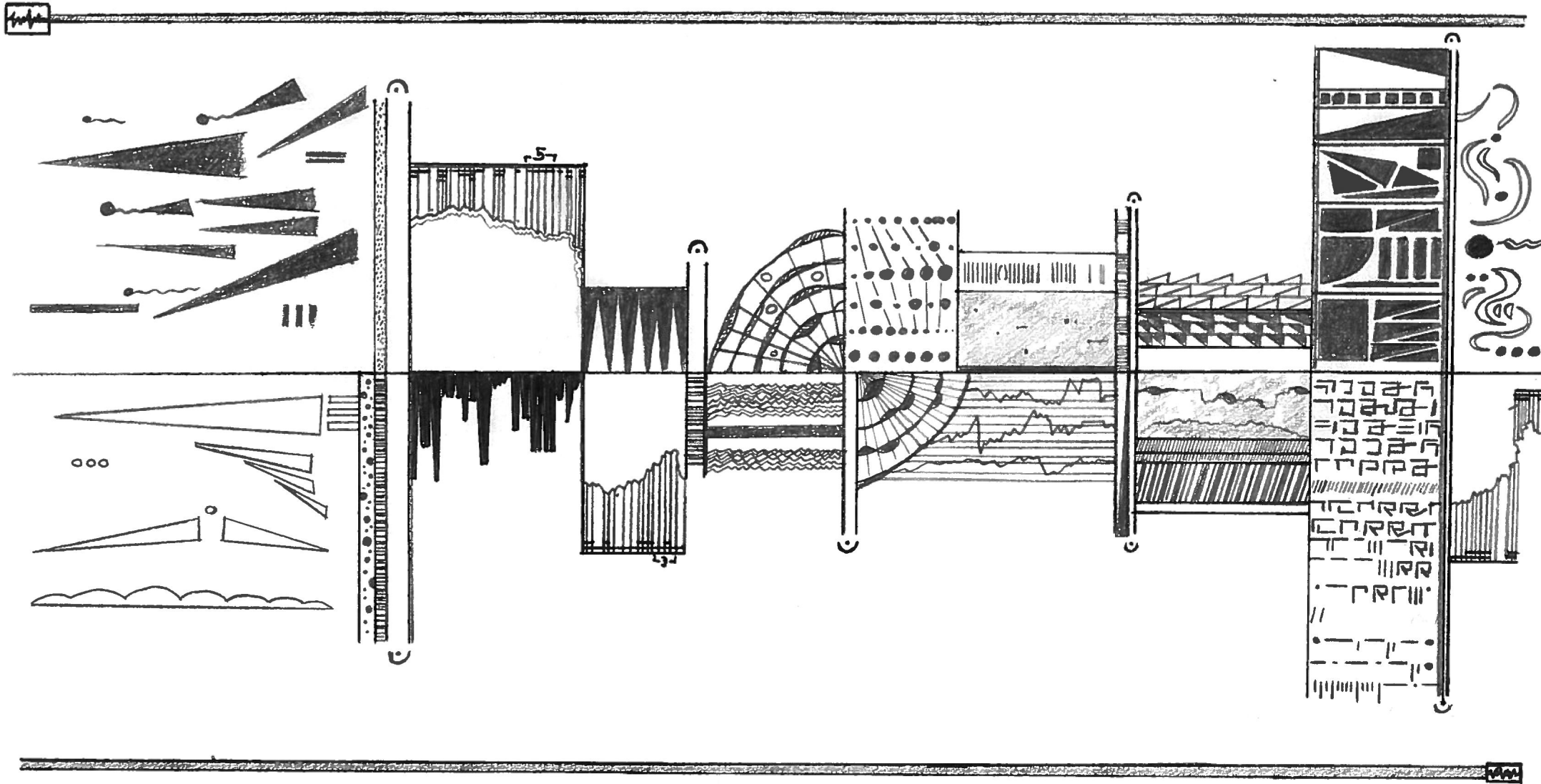



3 Sp. - 5 Sp.

(.)p.(.)

Wir-Wendung / Referenzrahmen

